

### USER INTERFACE

The user has a display and four keys for controlling status and programming of the instrument.

#### KEYS AND MENUS

UP key		Scrolls through the menu items Increases the values Activates manual defrost
DOWN key		Scrolls through the menu items Decreases the values Programmable by parameter
fnc key		ESC function (exit) Programmable by parameter
set key		Accesses the setpoint Accesses the menus Confirms the commands Displaying the alarms (if present)

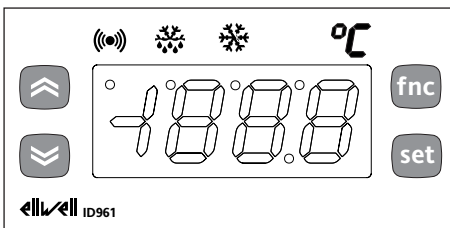

At start-up the instrument performs a Lamp Test; for few seconds the display and the leds blink, in order to verify their integrity and correct operation. The instrument has two main menus: the “Machine Status” and “Programming” menu.

#### ACCESSING AND USING MENUS

Resources are arranged in a menu, which can be accessed by pressing and quickly releasing the “set” key (“Machine Status” menu) or by holding down the “set” key for more than 5 seconds (“Programming” menu).

To access the contents of each folder, indicated by the relevant label, just press the “set” key once.

You can now scroll through the contents of each folder, modify it or use its functions.

#### LED

Position	Related Function	Status
	Compressor or relay 1	ON when the compressor is started up; blinking in case of delay, protection or blocked enabling
	Defrost	ON when defrosting; blinking in case of manual enabling
	Alarm	ON when the alarm is enabled; blinking when the alarm is silenced
	Setpoint	On for setting Setpoint

If you do not use the keyboard for over 15 seconds (time-out) or if you press the “fnc” key once, the last value shown on the display is confirmed and you return to the previous screen mask.

#### MACHINE STATUS MENU (See Machine Status Menu)

To access the “Machine Status” menu Press and quickly release the “set” key. If alarms are not present, the label “SEt” appears. By using the “UP” and “DOWN” keys you can scroll through the other folders in the menu:

- Pb1: probe 1 value folder;
- SEt: Setpoint setting folder.

#### Set Setting

Access the “Machine Status” menu by pressing and quickly releasing the “set” key. The label of the “Set” folder appears.

To display the Setpoint value press the “set” key again.

The value appears on the display.

To change the Setpoint value, use the “UP” and “DOWN” keys within 15 seconds.

If the parameter is LOC = y the Setpoint cannot be changed.

#### Displaying Probes

By pressing the “set” key when the appropriate label appears, the value of the probe associated to it is displayed.

#### PROGRAMMING MENU (See Programming Menu)

To enter the “Programming” menu, press the “set” key for more than 5 seconds. If specified, the access PASSWORD will be requested, (parameter “PA1”), and (if the password is correct) the label of the first folder will follow.

To scroll through the other folders, use the “UP” and “DOWN” keys.

If the password is wrong, the display will show the PA1 label again.

To enter the folder, press “set”. The label of the first visible parameter appears. To scroll through the other parameters, use the “UP” and “DOWN” keys; to change the parameter, press and release “set”, then

set the desired value using the “UP” and “DOWN” keys, and confirm with the “set” key to move to the next parameter.

**PLEASE NOTE:** It is suggested to switch-off and switch-on again the instrument everytime it is changed the configuration of the parameters: this prevents malfunctioning on regulation and delay time occurring.

#### PASSWORD

The password “PA1” allows access to programming parameters. In the standard configuration password is not present.

To enable (value≠0) and assign it the desired value, access the “Programming” menu, within the folder with the “diS” label. If password is enabled, you will see it at the entrance of the “Programming” menu (see the “Programming Menu” section).

#### MANUAL ACTIVATION OF THE DEFROSTING CYCLE

To manually activate the defrosting cycle, press the “UP” key for 5 seconds.

**(for defrost mode see table of parameters, folder “dEF”)**

#### COPY CARD

The Copy Card is an accessory connected to the TTL serial port which allows programming quickly the instrument parameters. The operation is performed as follows:

##### Format

This command allows copy card formatting, an operation recommended in case of first use.

Warning: if the copy card has been programmed, using the “Fr” the data entered are erased. This operation cannot be cancelled.

##### Upload

This operation loads the programming parameters from the instrument.

##### Download

This operation downloads to the instrument the programming parameters. The operations are performed accessing the folder identified by the “FPr” label and selecting, according to the case, “UL”, “dL” or “Fr” commands; the operation is confirmed by pressing the “set” key. If the operation is successful an “y” is displayed, on the contrary, if it fails a “n” will be displayed.

##### NOTE:

- **UPLOAD: instrument --> Copy Card**
- **DOWNLOAD: Copy Card --> instrument.**

## KEYBOARD LOCKING

The instrument includes a facility for disabling the keyboard, by programming the "Loc" parameter (see folder with "diS" label). If the keyboard is locked, you can still access the programming menu by pressing the "set" key.

The Setpoint can also be viewed.

## DIAGNOSTICS

The alarm condition is always signalled by the buzzer (if present) and by the led of

the alarm icon (🔊)

The alarm signal produced by a faulty thermostat probe (probe 1) is shown as E1 on the instrument display.

Error table

DISPLAY	ERROR
E1	Thermostat probe fault

When the sensor detects an error condition:

- the code E1 is displayed
- the compressor is activated as indicated by the "On" and "Off" parameters if programmed for the duty cycle or:

Ont	Of	Compressor output
0	0	OFF
0	>0	OFF
>0	0	ON
>0	>0	dc

## INSTALLATION

The instrument is designed for panel mounting. Make a hole of 29x71 mm, insert the instrument and fix it using the brackets provided. Do not mount the instrument in humid and/or dirty places; it is suitable for use in ordinary polluted places. Ventilate the place in proximity to the instrument colling slits.

## ELECTRICAL WIRING

**Attention! Never work on electrical connections when the machine is switched on.**

The instrument is equipped with screw terminal boards for connection of electrical cables with a diameter of 2.5 mm<sup>2</sup> (one conductor only per terminal for power connections).

For the capacity of the terminals, see the label on the instrument.

The relay contacts are voltage free. Do not exceed the maximum current allowed; in case of higher loads, use an appropriate contactor. Make sure the power supply voltage complies with the one required by the instrument.

In 12V versions the power supply must be

provided by a security transformer with the protection of a delayed 250 mA fuse. Probes have no connection polarity and can be extended using a regular bipolar cable (note that the extension of the probes affects the EMC electromagnetic compatibility of the instrument: pay extreme attention to wiring).

Probe cables, power supply cables and the TTL serial cables should be distant from power cables.

## CONDITIONS OF USE

### PERMITTED USE

For safety reasons the instrument must be installed and used according to the instruction provided and in particular, under normal conditions, parts bearing dangerous voltage levels must not be accessible.

The device must be adequately protected from water and dust as per the application and must also only be accessible via the use of tools (with the exception of the frontlet).

The device is ideally suited for use on household appliances and/or similar refrigeration equipment and has been tested with regard to the aspects concerning European reference standards on safety. It is classified as follows:

- according to its manufacture: as an automatic electronic control device to be incorporated by independent mounting;
- according to its automatic operating features: as a 1 B-type operated control type;
- as a Class A device in relation to the category and structure of the software

### UNPERMITTED USE

Any other use other than that permitted is de facto prohibited. It should be noted that the relay contacts provided are of a practical type and therefore subject to fault. Any protection devices required by product standards or dictated by common sense due to obvious safety reasons should be applied externally.

## LIABILITY AND RESIDUAL RISKS

Invensys Controls Italy S.r.L. shall not be liable for any damages deriving from:

- installation/use other than that prescribed and, in particular, that which does not comply with safety standards anticipated by regulations and/or those given herein;
- use on boards which do not guarantee adequate protection against electric shock, water or dust under the conditions of assembly applied;
- use on boards which allow access to dangerous parts without the use of tools;
- tampering with and/or alteration of the products;

## TECHNICAL DATA

Frontal panel protection: IP65.

Casing: plastic body in resin type PC+ABS UL94 V-0, inspection window in polycarbonate, buttons in thermoplastic resin.

Dimensions: frontal panel 74x32 mm, depth 60 mm.

Installation: on panel, with drilling template 71x29 mm (+0.2/-0.1 mm).

Use temperature: -5...55 °C.

Storage temperature: -30...85 °C.

Use environment humidity: 10...90 % RH (not condensing).

Storage environment humidity: 10...90% RH (not condensing).

Viewing range: -50...110 (NTC); -50...140 (PTC) °C without decimal point (selectable through parameter ndt) on 3 digit and half + mark display.

Analog inputs: one PTC or NTC input (selectable through parameter H00\*).

Serial: TTL for connection to Copy Card.

Digital outputs: 1 relay contact SPDT 8(3)A 250V~.

Measuring range: from -50 to 140 °C.

Accuracy: 0.5% better than end scale + 1 digit.

Resolution: 1 or 0.1 °C.

Consumption:

- model 230V: 3 VA max.
- model 12V: 1,5 VA max.

Power supply: 12 V~/± ±10% or 230V~ ±10% 50/60 Hz.

**\*NOTE 1: Switch off and switch on again the instrument after changing the input type NTC/PTC (par. H00)**

**NOTE 2: check the power supply specified on the instrument label; for relay and power supply capacities, contact the Sales Office).**

**PLEASE NOTE: The technical data included in this document, related to measurement (range, accuracy, resolution, etc.) refer to the instrument itself, and not to its equipment such as, for example, sensors. This means, for example, that sensor(s) error(s) shall be added to the instrument's one.**

Tab. 1 Parameter Table

PAR.	DESCRIPTION	RANGE	DEFAULT*	VALUE**	LEVEL***	U.M.
<b>COMPRESSOR REGULATOR (folder with "CP" label)</b>						
diF	differential. Relay compressor tripping differential. The compressor stops on reaching the Setpoint value (as indicated by the adjustment probe), and restarts at temperature value equal to the Setpoint plus the value of the differential. Note: the value 0 cannot be assumed.	0.1...30.0	2.0		1	°C/°F
HSE	Higher SET. Maximum possible setpoint value.	LSE...302	99.0		1	°C/°F
LSE	Lower SET. Minimum possible setpoint value.	-55.0...HSE	-50.0		1	°C/°F
<b>COMPRESSOR PROTECTIVE DEVICE (folder with "CP" label)</b>						
Ont (1)	On time (compressor). Compressor activation time in the event of faulty probe. If set to "1" with Offt at "0" the compressor is always on, while at Offt >0 it functions always in duty cycle mode.	0...250	0		1	min
Offt (1)	OFF time (compressor). Compressor in disabled state time in the event of a faulty probe. If set to "1" with Ont at "0" the compressor is always off, while at Ont >0 it functions always in duty cycle mode.	0...250	1		1	min
dOn	delay (at) On compressor. Delay time in activating the compressor relay after switch-on of instrument	0...250	0		1	sec
dOF	delay (after power) OFF. Delay after switch off; the indicated time must elapse between switch-off of the compressor relay and the successive switch-on.	0...250	0		1	min
dbi	delay between power-on. Delay between switch-ons; the indicated time must elapse between two successive switch-ons of the compressor.	0...250	0		1	min
OdO	delay Output (from power) On. Delay time in activating the outputs after switch-on of the instrument or after a power failure.	0...250	0		1	min
<b>DEFROSTING REGULATOR (folder with "dEF" label)</b>						
dit	defrost interval time. Interval between the start of two successive defrosting operations.	0...250	6h		1	hours
dCt	defrost Counting type. Selection of count mode for the defrosting interval. 0 = compressor operating hours (DIGIFROST® method); 1 = Real Time – appliance operating time; 2 = compressor stop.	0/1/2	1		1	flag
dOH	defrost Offset Hour. Start-of-defrosting delay time from start up of instrument.	0...59	0		1	min
dEt	defrost Endurance time. Defrosting time-out; determines duration of defrosting.	1...250	30min		1	min
dSt	defrost Stop temperature. Defrost stop temperature (defined by the probe).	-50.0... 150	8.0		1	°C/°F
dPO	defrost (at) Power On. Determines if at the start-up the instrument must enter defrosting (if the temperature measured allows this operation). y = yes; n = no.	n/y	n		1	flag
<b>DISPLAY (folder with "diS" label)</b>						
LOC	(keyboard) LOCK. Keyboard locking. However, you can enter parameter programming modify them along with the status of this parameter in order to allow keyboard locking. y = yes; n = no	n/y	n		1	flag
PA1	PASsword 1. When enabled (value other than 0) it constitutes the access key for level 1 parameters.	0...250	0		1	num
ndt(°)	number display type. View with decimal point. <b>y = yes</b> ; n = no	n/y	<b>y</b>		1	flag
CA1	CALibration 1. Positive or negative temperature value added to the value read by probe 1.	-12.0...12.0	0		1	°C/°F
ddl	defrost display Lock. Viewing mode during defrosting. 0 = shows the temperature read by the thermostat probe; 1 = locks the reading on the temperature value read by thermostat probe when defrosting starts, and until the next time the Setpoint value is reached; 2 = displays the label "deF" during defrosting, and until the next time the Setpoint value is reached.	0/1/2	1		1	flag
dro	display read-out. Select °C or °F for displaying the temperature read by the thermostat probe. 0 = °C, 1 = °F.	0/1	0		1	flag
<b>CONFIGURATION (folder with "CnF" label)</b>						
H00 (!)	Probe type selection, PTC or NTC. 0 = PTC; 1 = NTC.	0/1	<b>0/1</b>		1	flag
reL	release firmware. Device version: read only parameter.	/	/		1	/
tAb	tAble of parameters. Reserved: read only parameter.	/	/		1	/
<b>COPY CARD (folder with "Fpr" label)</b>						
UL	Up load. Programming parameter transfer from instrument to Copy Card.	/	/		1	/
dL	Down load. Programming parameter transfer from Copy Card to instrument	/	/		1	/
Fr	Format. Erasing all data in the copy card.	/	/		1	/
<b>PLEASE NOTE: using "Fr" parameter (copy card formatting) the data within the copy card will be lost permanently. The operation cannot be cancelled.</b>						
<b>(1) see Duty Cycle Diagram</b>						
* DEFAULT column: for H00 parameter default is depending on model						
* NOTE 1: Switch off and switch on again the instrument after changing the input type NTC/PTC (par. H00)						
** VALUE column: to be filled manually, with customized settings (if different from the default value).						
*** LEVEL column: indicates the level of visibility of parameters accessible by PASSWORD (see the related paragraph)						
<b>(!) WARNING!</b>						
• If one or more of these parameters highlighted with (!) are modified, the controller must be switched off and switched on again to ensure correct operation.						
• It is strongly recommended, anyway to switch off and switch on again the controller anytime parameters have been changed to prevent malfunctioning on configuration and/or ongoing timings						
<b>(*) Viewing range: -50...110 (NTC); -50...140 (PTC) °C without decimal point (selectable through parameter on 3 digit &amp; 1/2 + mark display.</b>						

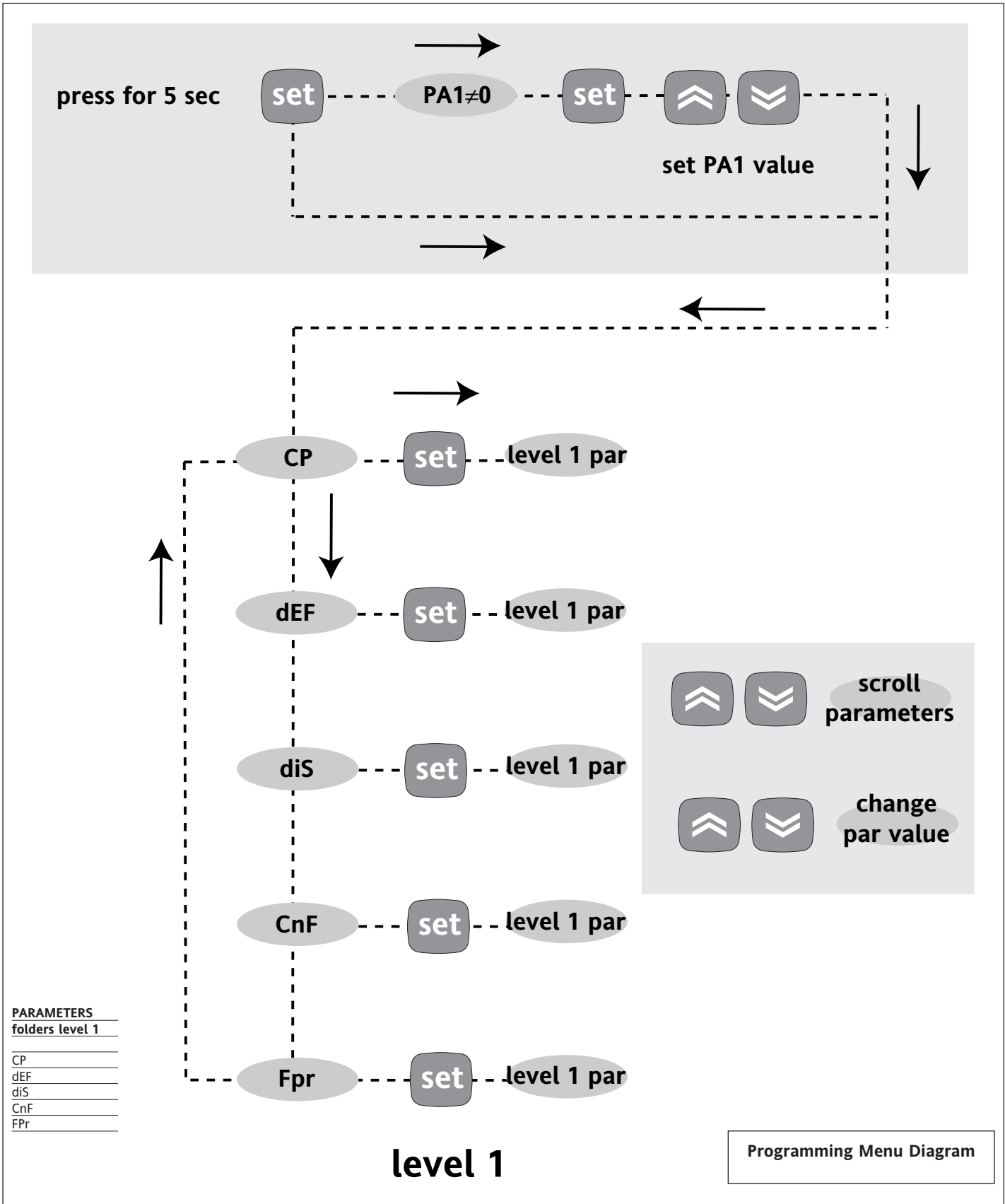
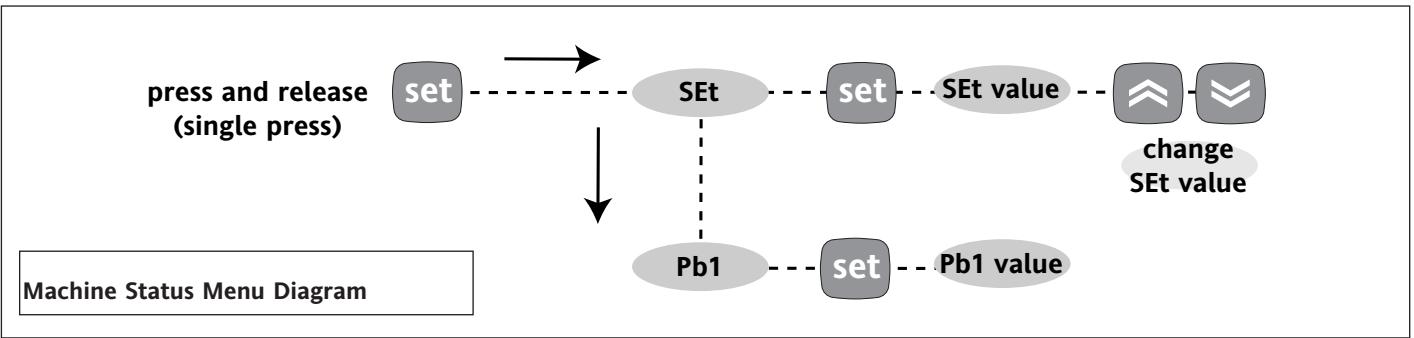

## Duty Cycle Diagram

Ont, OFt parameters programmed for Duty Cycle

Ont	OFt	Output compressor
0	0	OFF
0	>0	OFF
>0	0	ON
>0	>0	dc

When the sensor detects an error condition:

- the code E1 is displayed
- the compressor is activated as indicated by the "Ont" and "OFt" parameters if programmed for the duty cycle or:

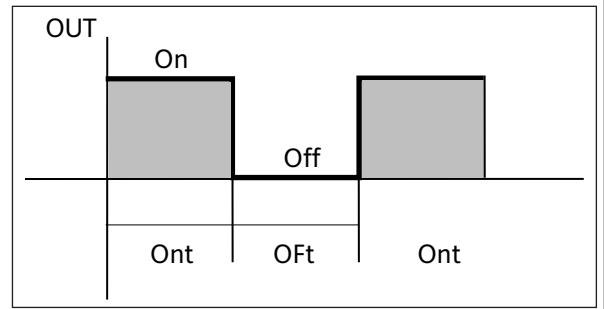

Wiring diagram

### TERMINALS (12 and 230V)

1 - 2	N.C. compressor relay <b>OUT</b>
1 - 3	N.O. compressor relay <b>OUT</b>
6 - 7	Power supply • model 230V: 3 VA max. • model 12V: 1,5 VA max.
8 - 10	Probe 1 input <b>Pb1 (thermostat and defrost)</b>
A	TTL input for Copy Card

#### NOTE:

- User Default Settings
- For relay capacities check on the instrument label.  
In the diagram it is shown relays with 8(3) 1/2 hp 250V capability and 12/230V supply

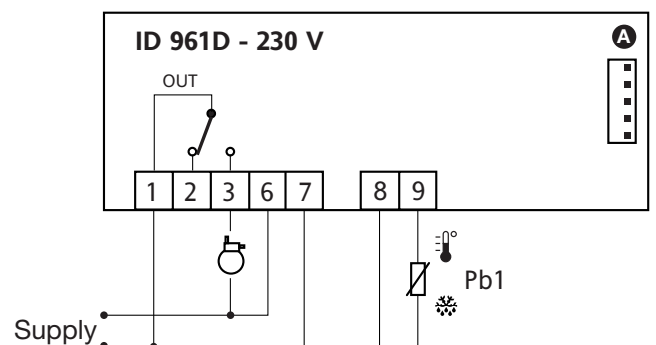
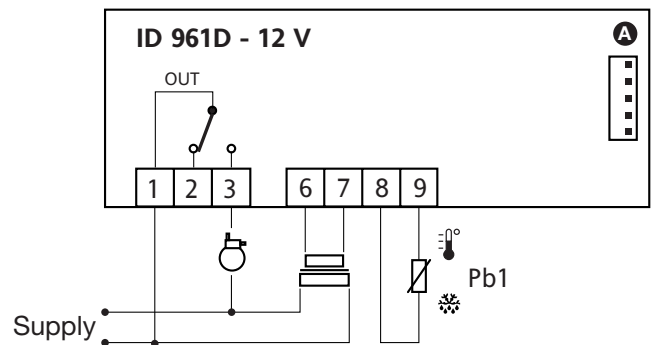

**Invensys Controls Italy s.r.l.**  
via dell'Industria, 15 Zona Industriale Paludi  
32010 Pieve d'Alpago (BL) ITALY  
Telephone +39 0437 986111  
Facsimile +39 0437 989066  
Internet <http://www.climate-eu.invensys.com>

4/2003 eng  
cod. 9IS43014

## DISCLAIMER

This manual and its contents remain the sole property of Invensys Controls Italy s.r.l., and shall not be reproduced or distributed without authorization. Although great care has been exercised in the preparation of this document, Invensys Controls Italy s.r.l., its employees or its vendors, cannot accept any liability whatsoever connected with its use. Invensys Controls Italy s.r.l. reserves the right to make any changes or improvements without prior notice.